



**RAM 5000 • RAM 5100 • RAM 5200s**  
**SLIDE - INSTRUCTION MANUAL**

# INSTRUCTION MANUAL

HIGH TRAFFIC SLIDING  
GATE OPERATORS



**RAM 5000**  
 $\frac{1}{2}$  Hp

---



**RAM 5100**  
 $\frac{3}{4}$  Hp

---



**RAM 5200**  
1 Hp - 115VAC or 230VAC

---



For Class I, II, III, IV  
Vehicular Gate  
Operators

# TABLE OF CONTENTS

IMPORTANT SAFETY INSTRUCTIONS .....	1	LED LAYOUT - LOGIC & AC DRIVER PCBs .....	11
IMPORTANT SAFETY REQUIREMENTS .....	2	LOGIC CONTROL BOARD	
RESPONSIBILITIES OF THE GATE TECH .....	3	DIP SWITCHES - FUNCTIONS .....	12
IMPORTANT INFO FOR THE HOMEOWNER		DIP SWITCHES - M.E.P. (MONITORED	
WARRANTY INFORMATION .....	4	ENTRAPMENT PROTECTION) .....	13
BEFORE YOUR TECH LEAVES .....	4	PLUGS - M.E.P. (MONITORED ENTRAPMENT	
AFTER YOUR TECH LEAVES .....	4	PROTECTION) .....	13
UL GATE CLASSIFICATIONS .....	5	PLUGS - FUNCTIONS .....	14
GENERAL SPECIFICATIONS .....	5	AC DRIVER CONTROL BOARD	
ELECTRICAL CONNECTIONS .....	5	DIP SWITCHES .....	15
WIRE GAUGE .....	5	PUSHBUTTONS .....	15
INSTALLATION SPECS .....	6	PLUGS - FUNCTIONS .....	16
TYPES OF INSTALLATIONS .....	7	PRIMARY/SECONDARY - BI-PARTING GATES .....	17
LOOP SENSOR LOCATIONS & INSTALLATIONS .....	8	FOOT PEDAL EMERGENCY RELEASE .....	17
GATE TRAVEL ADJUSTMENT .....	8	FACTORY WIRING .....	18
IDLER WHEEL / CHAIN HEIGHT ADJUSTMENT .....	8	M.E.P. QUICK SETUP GUIDE .....	19
ENTRAPMENT & SAFETY PROTECTION .....	9	EXPLODED VIEW .....	20
ENTRAPMENT PROTECTION AREA .....	10	B.O.M. (BILL OF MATERIALS) .....	21-22



**ONLY A QUALIFIED, EXPERIENCED GATE TECHNICIAN SHOULD  
INSTALL, MAINTAIN OR SERVICE THIS OR ANY GATE OPERATOR**

## IMPORTANT SAFETY INSTRUCTIONS

**WARNING** – To reduce the risk of injury or death:

1. READ AND FOLLOW ALL INSTRUCTIONS.
2. Never let children operate or play with gate controls. Keep the remote control away from children.
3. Always keep people and objects away from the gate. **NO ONE SHOULD CROSS THE PATH OF THE MOVING GATE.**
4. Test the gate operator monthly. The gate **MUST** reverse on contact with a rigid object or stop when an object activates the non-contact sensors. After adjusting the force or the limit of travel, retest the gate operator. Failure to adjust and retest the gate operator properly can increase the risk of injury or death.
5. Use the emergency release only when the gate is not moving.
6. **KEEP GATES PROPERLY MAINTAINED.** Read the user's manual. Have only qualified service persons make repairs to gate hardware.
7. The entrance is for vehicles only. Pedestrians must use separate entrance.
8. **SAVE THESE INSTRUCTIONS.**

## IMPORTANT SAFETY REQUIREMENTS BY UL STANDARDS

a) Install the gate operator only when:

1) The operator is appropriate for the construction of the gate and the usage Class of the gate,

2) All openings of a horizontal slide gate are guarded or screened from the bottom of the gate to a minimum of 1.83 m (6 ft) above the ground to prevent a 57.2 mm (2-1/4 inch) diameter sphere from passing through the openings anywhere in the gate, and in that portion of the adjacent fence that the gate covers in the open position,

3) All areas of the moving vertical pivot gate panel from the bottom of the gate to the top of the gate or a minimum of 1.83 m (72 in) above grade, whichever is less, that pass by a fixed stationary object, and in the area of the adjacent fence that the gate covers during the travel of the gate, shall be designed, guarded or screened to prevent a 57 mm (2-1/4 in) diameter sphere from passing through such areas.

4) All exposed pinch points are eliminated or guarded, and

5) Guarding is supplied for exposed rollers.

6) The operator instructions shall list the maximum number of open and close entrapment protection devices capable of being connected to the operator.

b) The operator is intended for installation only on gates used for vehicles. Pedestrians must be supplied with a separate access opening. The pedestrian access opening shall be designed to promote pedestrian usage. Locate the gate such that persons will not come in contact with the vehicular gate during the entire path of travel of the vehicular gate.

c) The gate must be installed in a location so that enough clearance is supplied between the gate and adjacent structures when opening and closing to reduce the risk of entrapment. Swinging gates shall not open into public access areas.

d) The gate must be properly installed and work freely in both directions prior to the installation of the gate operator. Do not over-tighten the operator clutch or pressure relief valve to compensate for an improperly installed, improperly functioning, or damaged gate.

e) For gate operators utilizing Type D protection:

1) The gate operator controls must be placed so that the user has full view of the gate area when the gate is moving,

2) The placard as required by 62.1.6 shall be placed adjacent to the controls,

3) An automatic closing device (such as a timer, loop sensor, or similar device) shall not be employed, and

4) No other activation device shall be connected.

f) Permanently mounted controls intended for user activation must be located at least 1.83 m (6ft) away from any moving part of the gate and where the user is prevented from reaching over, under, around or through the gate to operate the controls.

Exception: Emergency access controls only accessible by authorized personnel (e.g. fire, police, EMS) may be placed at any location in the line-of-sight of the gate.

g) The Stop and/or Reset button must be located in the line-of-sight of the gate. Activation of the reset control shall not cause the operator to start.

h) A minimum of two (2) WARNING SIGNS shall be installed, in the area of the gate. Each placard is to be visible by persons located on the side of the gate on which the placard is installed. Also see 62.1.1.

i) For gate operators utilizing a non-contact sensor in accordance with 32.1.1:

1) See instructions on the placement of non-contact sensors for each Type of application,

2) Care shall be exercised to reduce the risk of nuisance tripping, such as when a vehicle, trips the sensor while the gate is still moving, and

3) One or more non-contact sensors shall be located where the risk of entrapment or obstruction exists, such as the perimeter reachable by a moving gate or barrier.

j) For a gate operator utilizing a contact sensor in accordance with 32.1.1:

1) One or more contact sensors shall be located where the risk of entrapment or obstruction exists, such as at the leading edge, trailing edge, and post-mounted both inside and outside of a vehicular horizontal slide gate.

2) One or more contact sensors shall be located at the bottom edge of a vehicular vertical lift gate.

3) One or more contact sensors shall be located at the pinch point of a vehicular vertical pivot gate.

4) A hardwired contact sensor shall be located and its wiring arranged so that the communication between the sensor and the gate operator is not subjected to mechanical damage.

5) A wireless device such as one that transmits radio frequency (RF) signals to the gate operator for entrapment protection functions shall be located where the transmission of the signals are not obstructed or impeded by building structures, natural landscaping or similar obstruction. A wireless device shall function under the intended end-use conditions.

6) One or more contact sensors shall be located on the inside and outside leading edge of a swing gate. Additionally, if the bottom edge of a swing gate is greater than 152 mm (6 in) but less than 406 mm (16 in) above the ground at any point in its arc of travel, one or more contact sensors shall be located on the bottom edge.

7) One or more contact sensors shall be located at the bottom edge of a vertical barrier (arm)

# RESPONSIBILITIES OF THE INSTALLER/GATE TECHNICIAN

\*\*\* RAMSET GATE OPERATORS SHOULD ONLY BE INSTALLED, MAINTAINED OR SERVICED BY A QUALIFIED, EXPERIENCED GATE TECHNICIAN WITH THE APPROPRIATE TRAINING.

- READ & UNDERSTAND THE ENTIRE INSTRUCTION MANUAL BEFORE STARTING ANY INSTALLATION
- USE THE PROPER OPERATOR. TAKE INTO CONSIDERATION:
  - CATEGORY (SLIDE, SWING OR OVERHEAD)
  - TYPE (STANDARD, UPHILL, COMPACT, CANTILEVER...ETC.)
    - All measurements and capabilities in this manual are for standard installations. All other types of installations may reduce the capabilities and measurements in this manual.
  - GATE CLASS (I, II, III or IV) see UL gate classification section
  - GATE WEIGHT & TRAVEL
- DO NOT EXCEED THE EQUIPMENT'S SPECIFICATIONS AND CAPABILITIES OF THE OPERATOR AND HARDWARE.
- MAKE SURE THE OPERATOR HAS A SECURE FOUNDATION (see installation specifications section)
- WHEN SERVICING A GATE OPERATOR ALWAYS PERFORM AN INSPECTION OF THE ENTIRE GATE SYSTEM (GATE, GATE OPERATOR, INSTALLATION & ELECTRICAL / WIRING) AND MAKE ANY AND ALL SUGGESTIONS, TO THE PROPERTY OWNER, TO BRING THEIR GATE SYSTEM INTO COMPLIANCE WITH ALL UL 325 AND ASTM F2200 SAFETY STANDARDS.
- A SIGNED WAIVER DOES NOT NULIFY THE INSTALLER / TECHNICIANS LIABILITY DUE TO THE FACT THAT IT HAS NO SUBSTANCE IN LITIGATION INVOLVING AN INJURED PARTY WHO DID NOT SIGN THE WAIVER.
- WHEN NECESSARY, INSTALL SURGE / LIGHTNING SUPPRESSION AND GROUND RODS.
- SAFETY IS THE PRIMARY CONCERN WHEN INSTALLING A GATE OPERATOR
- MAKE SURE TO FOLLOW ALL UL 325 AND ASTM F2200 SAFETY CODES.
- ANY NON-AUTOMATED GATE THAT IS TO BE AUTOMATED SHALL BE UPGRADED TO CONFORM TO THE ALL ASTM F2200 STANDARDS.
- WHEN THE GATE OPERATOR REQUIRES REPLACEMENT, THE EXISTING GATE SHALL BE UPGRADED TO CONFORM TO ALL ASTM F2200 AND UL325 SAFETY STANDARDS.
- WHEN THE GATE OF AN AUTOMATED GATE SYSTEM REQUIRES REPLACEMENT, THE NEW GATE SHALL CONFORM TO ALL ASTM F2200 STANDARDS.
- ONLY USE UL 325 COMPLIANT ACCESSORIES & EQUIPMENT.
- ONLY USE THE APPROVED ENTRAPMENT PROTECTION DEVICES LISTED IN THIS MANUAL.
- MAKE SURE ALL ENTRAPMENT ZONES ARE PROTECTED BY APPROVED ENTRAPMENT PROTECTION DEVICES.
  - ENTRAPMENT ZONE: Locations between a moving gate and a counter opposing edge or surface where entrapment is possible up to 6 ft. above grade. Such locations occur if during any point in travel the gap between a moving gate and fixed counter opposing edges or surfaces is less than 16 inches.
- APPROVED ENTRAPMENT PROTECTION DEVICES:

EMX NIR 50-325  
EMX IRB-RET  
EMX IRB-MON

OMRON E3K-R10K4 - NR-1  
SECO-LARM E931-S50RRGQ  
SECO-LARM E936-S45RRGQ

MILLER EDGE - PRIME GUARD  
MILLER EDGE - REFLECTI GUARD

- NO SAFETY DEVICES SHOULD EVER BE BYPASSED, REMOVED OR OMITTED BY THE INSTALLER / TECHNICIAN.
- ALL CONTROLS MUST BE LOCATED AT LEAST 6 FEET AWAY FROM ANY PART OF THE GATE OPERATOR OR MOVING GATE AT ALL TIMES.
- INTERIOR CONTROL STATIONS SHOULD BE INSTALLED SO THAT THE USER HAS A DIRECT LINE OF SIGHT TO THE GATE AREA BEING CONTROLLED.
- PHOTO EYES SHOULD BE INSTALLED WITHIN 5 INCHES FROM THE GATE PANEL AND A MAXIMUM HEIGHT OF 27.5 INCHES.
- ALL EXPOSED PINCH POINTS ARE ELIMINATED OR GUARDED.
- ALL EXPOSED ROLLERS ARE GUARDED.
- WARNING SIGNS MUST BE PERMANENTLY AFFIXED TO THE GATE PANEL IN A HIGHLY VISIBLE PLACE THAT CAN BE EASILY SEEN FROM BOTH SIDES OF THE GATE.
- FOR PEDESTRIAN ACCESS IN THE VICINITY OF AN AUTOMATED VEHICULAR GATE, A SEPARATE PEDESTRIAN GATE SHALL BE PROVIDED.
  - THE PEDESTRIAN GATE SHALL BE INSTALLED IN A LOCATION SUCH THAT A PEDESTRIAN SHALL NOT COME IN CONTACT WITH A MOVING VEHICULAR ACCESS GATE.
  - A PEDESTRIAN GATE SHALL NOT BE INCORPORATED INTO AN AUTOMATED VEHICULAR GATE PANEL.
- POSITIVE STOPS SHALL BE REQUIRED TO LIMIT TRAVEL TO THE DESIGNED FULLY OPEN AND FULLY CLOSED POSITIONS. THESE STOPS SHALL BE INSTALLED AT EITHER THE TOP OF THE GATE, OR AT THE BOTTOM OF THE GATE WHERE SUCH STOPS SHALL HORIZONTALLY OR VERTICALLY PROJECT NO MORE THAN IS REQUIRED TO PERFORM THEIR INTENDED FUNCTION.
- GATES SHALL BE DESIGNED, CONSTRUCTED AND INSTALLED SUCH THAT THEIR MOVEMENT SHALL NOT BE INITIATED BY GRAVITY WHEN AN AUTOMATIC OPERATOR IS DISCONNECTED.
- ALL OPENINGS SHALL BE DESIGNED, GUARDED, OR SCREENED FROM THE BOTTOM OF THE GATE TO THE TOP OF THE GATE OR A MINIMUM OF 72" ABOVE GRADE, WHICHEVER IS LESS, TO PREVENT A 2 1/4" DIAMETER SPHERE FROM PASSING THROUGH THE OPENINGS ANYWHERE IN THE GATE, AND IN THAT PORTION OF THE ADJACENT FENCE THAT THE GATE COVERS IN THE OPEN POSITION. THE GATE PANEL SHALL INCLUDE THE ENTIRE SECTION OF THE MOVING GATE, INCLUDING ANY BACK FRAME OR COUNTERBALANCE PORTION OF THE GATE.

# IMPORTANT INFORMATION FOR THE HOMEOWNER

## **WARRANTY INFORMATION:**

- Completely fill out and mail-in (Via certified mail) your WARRANTY REGISTRATION CARD within 90 days of the installation to:  
Ramset Automatic Gate Systems, Inc.  
9116 De Garmo Ave  
Sun Valley, CA 91352
- The WARRANTY REGISTRATION CARD can also be filled out on our website <RAMSETINC.COM>
- Read and understand your warranty certificate.
- Ramset's warranty only covers the operator against manufacturer's defects.
- Ask the installer/technician what his warranty on their service is. (Labor is not covered under Ramset's warranty).
- All Warranty issues & claims must be redeemed by a gate technician.

## **BEFORE YOUR TECHNICIAN LEAVES:**

- Ask your technician about all of the features of your new Ramset Gate Operator.
- Make sure all of your accessories are properly functioning (remotes, keypads, telephone entry systems, exit loops, safety loops, phantom loops, edge sensors...etc.)
- Make sure that your technician gives you the following documentation that is enclosed inside every operator.  
1) Warranty Registration Card      2) Warranty Certificate      3) Inspection Sheet
- Have your technician give you a demonstration of how to use the emergency release.  
1) Foot Pedal      2) Chain Drop      3) Hand lever release      4) Hand trolley release
- Have the technician show you the gate operator breaker in your electrical panel.  
- A label is provided with every operator to clearly mark the breaker.
- Make sure the safety photo eyes or edges are properly installed on your gate system.  
- 1 Photo eye / edge protecting the closing direction (ON ALL GATE SYSTEMS)  
- 1 Photo eye / edge protecting the opening direction (ONLY MANDATORY ON SLIDE GATE SYSTEMS)
- THIS ENTRANCE IS FOR VEHICLES ONLY. Pedestrians should be provided with a separate entrance.  
- The pedestrian gate should be located so that the moving vehicular access gate does not cross or come in contact with the pedestrian gate at any time.  
- A pedestrian gate shall not be incorporated into an automated vehicular gate panel.
- Warning signs must be mounted on each side of the gate (inside and outside) in a highly visible area.

## **AFTER YOUR TECHNICIAN LEAVES:**

- Always keep a good relationship with your technician and keep thier phone number handy for future maintenance or emergencies.
- **All issues should be directed to your technician.**
- Whenever possible, turn off the circuit breaker to the operator before using the emergency release system.
- No one except a qualified, experienced gate technician should ever remove the cover or access door from the gate operator.
- Only a qualified, experienced gate technician should work on, maintain, clean, repair or service the gate operator.
- Keep gates properly maintained. Have a qualified, experienced gate technician service the gate operator system & gate hardware approximately every 6 months to a year.
- Frequently check all safety devices for proper operation. This includes photo eyes, loops, edges...etc.
- Frequently check your emergency release and battery back-up system (if applicable) for proper operation.
- Never let children operate or play with gate controls. Keep the controls away from children.
- Never let children play in the area around the gate or gate operator.
- Never let anyone ride, climb under or climb over the gate.
- Always keep people, children and objects away from the gate while the gate is in operation.
- No one should cross the area of a moving gate.
- Keep the area around the gate operator clean and free of debris.
- Keep the area around the gate operator free from insects and rodents. Insects and rodents can cause damage to the gate operator, which is not covered by the warranty.

## UL GATE CLASSIFICATIONS

**CLASS I - Residential Vehicular Gate Operator** - A vehicular gate operator (or system) intended for use in garages or parking areas associated with a residence of one-to four single families.

**CLASS II - Commercial / General Access Vehicular Gate Operator** - A vehicular gate operator (or system) intended for use in a commercial location or building such as a multi-family housing unit (five or more single units), hotels, garages, retail stores, or other buildings accessible by or servicing the general public.

**CLASS III - Industrial / Limited Access Vehicular Gate Operator** - A vehicular gate operator (or system) intended for use in an industrial location or building such as a factory or loading dock area or other locations not accessible by or intended to service the general public.

**CLASS IV - Restricted Access Vehicular Gate Operator** - A vehicular gate operator (or system) intended for use in a guarded industrial location or building such as an airport security area or other restricted access location not servicing the general public, in which unauthorized access is prevented via supervision by security personnel.

## GENERAL SPECIFICATIONS

MODEL	RAM 5000	RAM 5100	RAM 5200-115	RAM 5200-230
MAX GATE WEIGHT	1000 LBS	2000 LBS	2500 LBS	3000 LBS
MAX GATE TRAVEL	40'			
MOTOR	1/2Hp, 115VAC, 4.5A, 1625 rpm	3/4Hp, 115VAC, 8.5A, 1625 rpm	1Hp, 115VAC, 8.5A, 1625 rpm	1Hp, 230VAC, 4.5A, 1625rpm
MOTOR CAPACITOR	65uF, 240V, 50/60Hz	50uF & 65uF, 240V, 50/60Hz	75uF & 75uF, 240V, 50/60Hz	35uF, 370V, 50/60Hz
DUTY CYCLE	CONTINUOUS DUTY			
APPLICATION	RESIDENTIAL / COMMERCIAL / INDUSTRIAL			
CHASSIS PLATING	3/16" - GOLD / ZINC PLATED			
EMERGENCY RELEASE	FOOT PEDAL			
DIMENSIONS	16 1/2" x 22 1/2" x 26" (with foot pedal)			
GATE SPEED	1 FOOT PER SECOND			

## RECOMMENDED ELECTRICAL CONNECTION

A 3-wire, 115VAC or 230VAC electrical circuit with a 15 amp independent (dedicated) circuit breaker for a single operator and a 20 amp independent (dedicated) circuit breaker for primary / secondary systems. Low voltage control wires must be run in a separate conduit to the operator.

**NOTE: ALWAYS CONSULT AND FOLLOW ALL LOCAL BUILDING AND ELECTRICAL CODES PRIOR TO INSTALLATION. PERMANENT WIRING IS TO BE EMPLOYED AS REQUIRED BY LOCAL CODES. GROUNDING THE OPERATOR IS ESSENTIAL FOR SAFETY AND PROPER OPERATION.**

## RECOMMENDED WIRE GAUGE

MODEL	HP	VOLTS (AC)	RUN	START	12GA	10GA	8GA	6GA
R5000	1/2	115	4.5A	5.0A	up to 225'	226'-370'	371'-550'	551'-925'
R5100	3/4	115	8.5A	9.0A	up to 115'	116'-195'	196'-290'	291'-495'
R5200-115	1	115	9.4A	9.9A	N/A	up to 175'	176'-265'	266'-445'
R5200-230	1	230	5.0A	5.5A	up to 200'	201' - 325'	326' - 485'	486' - 825'

# INSTALLATION SPECIFICATIONS



**WARNING** Do not exceed the specifications. The warranty on your gate operator will be void if the installation exceeds the recommended specifications.

*All sliding gate operators are factory preset for (LH) left-hand installations.*

## CONCRETE PAD CONSTRUCTION

Dimensions given for the pad are based on soil bearing shear of 2000 P.S.F. These figures may have to be adjusted depending on local soil conditions.

1. Construct form for mounting the pad according to dimensions shown in Figure 1, 2 & 3.
2. Locate the mounting pad according to dimensions given in illustration.
3. Level the top edge of the form.
4. Set reinforcing bars and wire mesh
5. Mix concrete, pour mixture into form. Level and finish surface after pouring is complete.
6. Allow the pad to cure for 48 hours, and remove the forms.

**Figure 1**

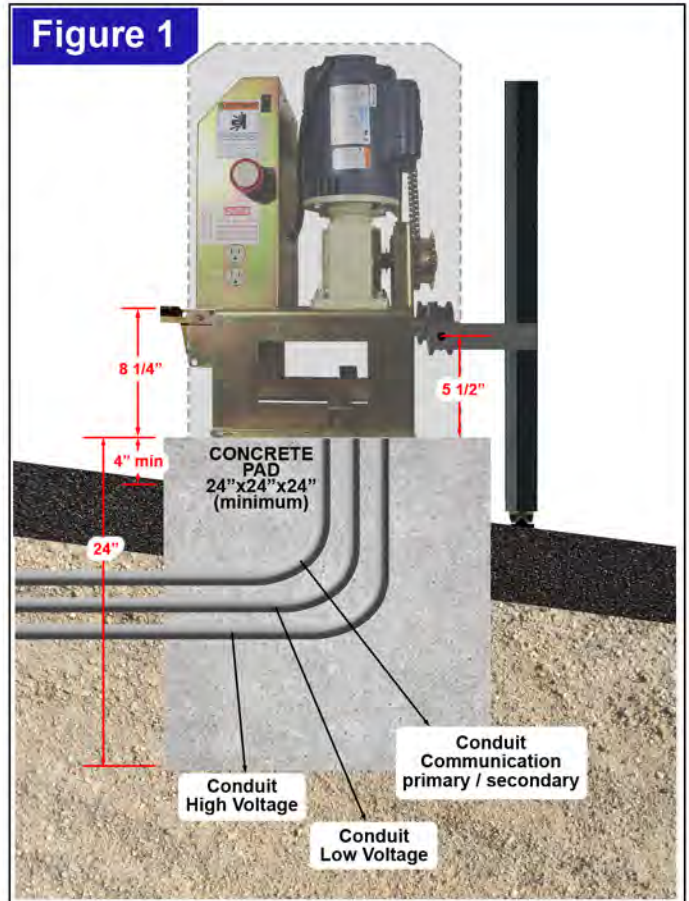

**Figure 2**

Top View  
Gate Open  
LH Front Installation

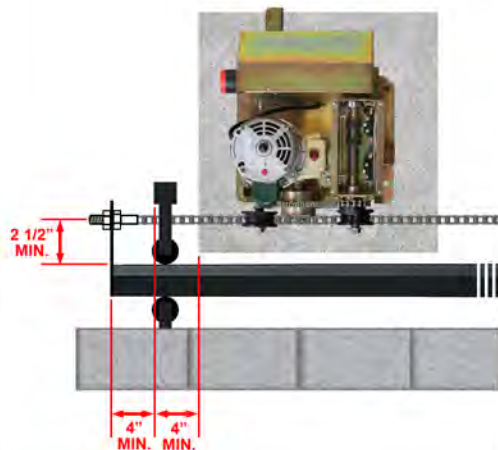

**Figure 3**

Top View  
Gate Closed  
LH Front Installation

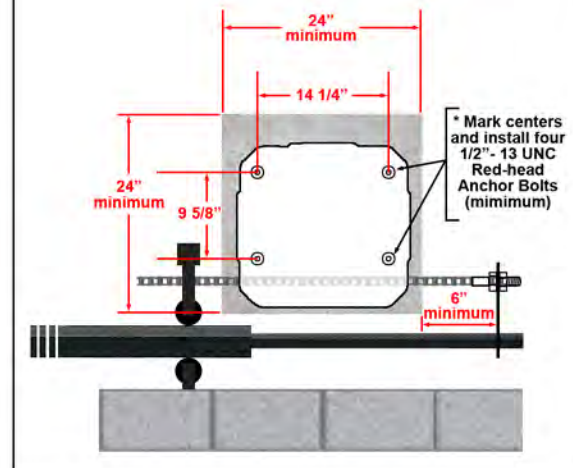

# RAM 5000s - TYPES OF INSTALLATIONS

**Figure 4**

TOP VIEW

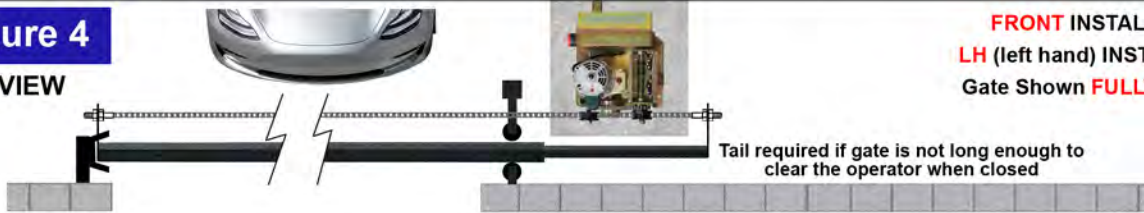

**FRONT** INSTALLATION  
**LH** (left hand) INSTALLATION  
 Gate Shown **FULLY CLOSED**

OUTSIDE VIEW

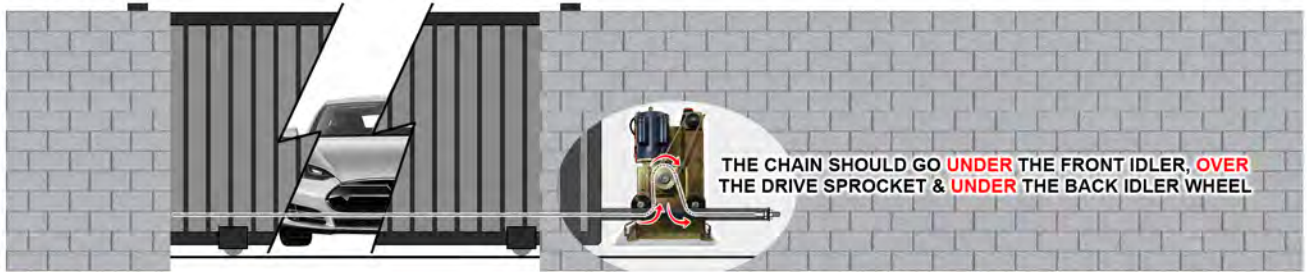

**WARNING**

**MAKE SURE ALL EXPOSED PINCH POINTS ARE ELIMINATED OR GUARDED.**

**Figure 5**

TOP VIEW

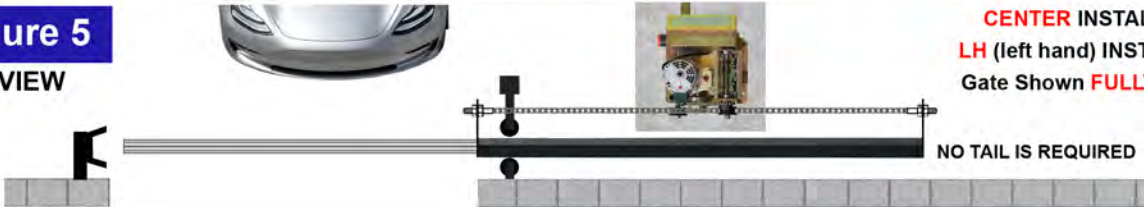

**CENTER** INSTALLATION  
**LH** (left hand) INSTALLATION  
 Gate Shown **FULLY OPENED**

OUTSIDE VIEW

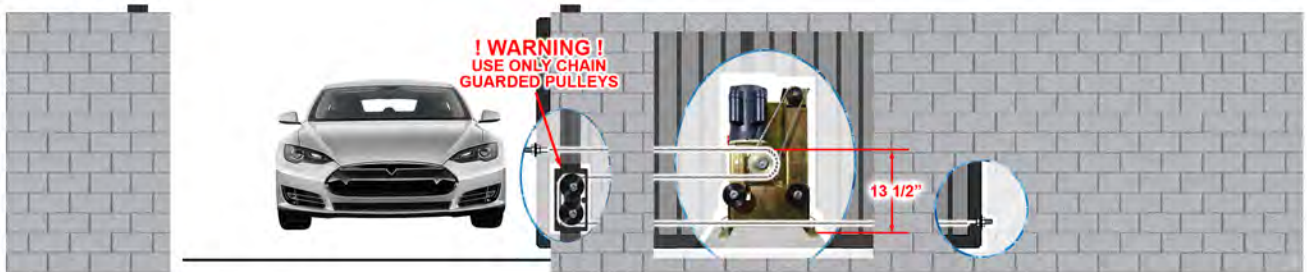

**Figure 6**

TOP VIEW



**REAR** INSTALLATION  
**LH** (left hand) INSTALLATION  
 Gate Shown **FULLY OPENED**

OUTSIDE VIEW

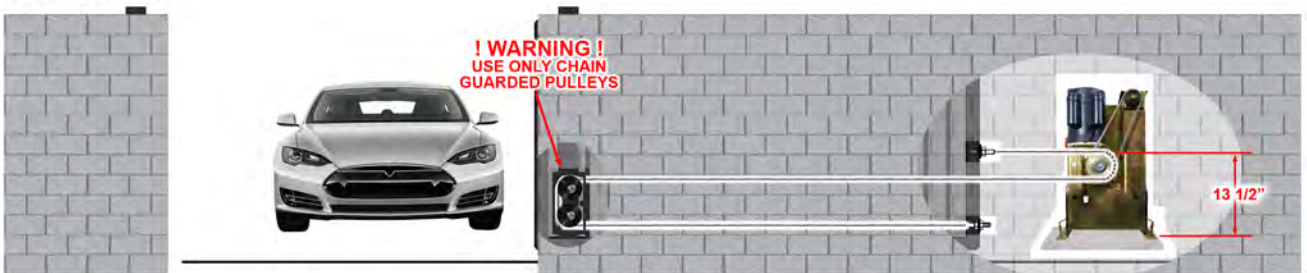



## LOOP LOCATION & INSTALLATION



### WARNING

LOOP SENSORS CANNOT BE USED TO MEET UL325 REQUIREMENTS. PHOTO EYES, EDGES OR THE EQUIVALENT ARE NEEDED TO MEET UL325 REQUIREMENTS.

Figure 7

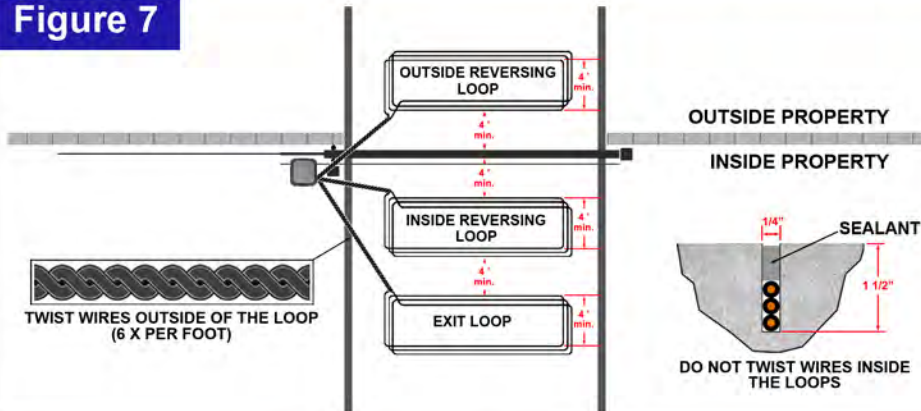

- **REVERSING LOOPS**  
On the ground floor, prevents the gate from closing.
- **EXIT LOOP**  
On the ground floor, opens the gate.

## GATE TRAVEL ADJUSTMENT



### WARNING

ALWAYS TURN OFF ALL POWER BEFORE ATTEMPTING TO ADJUST THE GATE TRAVEL

Figure 8

#### ADJUSTING THE GATE TRAVEL

1. Depress the spring loaded bracket.
2. With your finger, turn each adjustment nut to the desired position.
3. Run the gate fully open and closed. Make small adjustments until the limits are set.

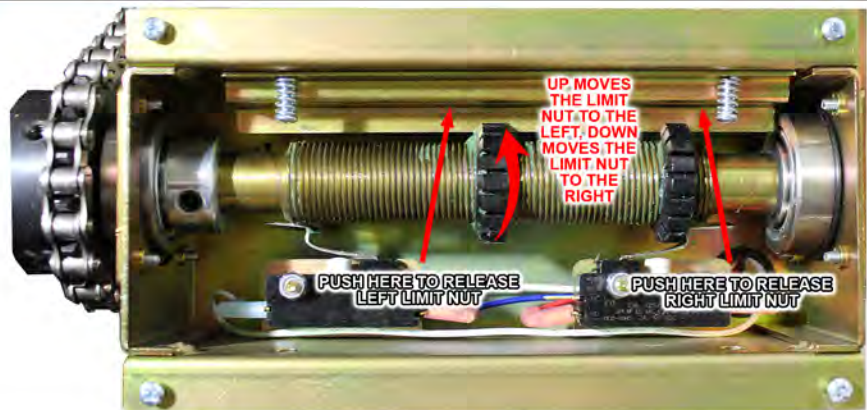

## IDLER WHEEL / CHAIN HEIGHT ADJUSTMENT

Figure 9

- 3 Idler wheel adjustment heights.



- On the middle and high adjustments, the cover will need to be modified to accommodate for the higher chain level.



- Use the higher adjustment for longer gates.



## ENTRAPMENT & SAFETY PROTECTION



### WARNING

**ALL ENTRAPMENT AREAS NEED TO BE PROTECTED BY A MONITORED ENTRAPMENT PROTECTION DEVICE.**

- Every slide gate operator requires a minimum of 2 entrapment protection devices in both directions. One in each direction is covered by the inherent ERD system (Type A). Therefore, at least one additional photo eye, edge sensor or equivalent is required to be added, by the installer, in each direction.
- Since every installation is different, it is up to a qualified, trained technician to make sure that ALL entrapment areas are protected by an entrapment protection device.
- It is also up to a qualified, trained technician to determine what types and how many devices are needed.
- A Maximum of 10 monitored entrapment devices may be connected to your operator, depending on direction of travel and type of device.

### Horizontal slide Entrapment protection types A, B1, B2 or D

Note – The same type of device shall not be utilized for both entrapment protection means.

<b>Type A</b>	Inherent entrapment protection system.
<b>Type B1</b>	Non-contact sensor (photoelectric sensor or the equivalent).
<b>Type B2</b>	Contact sensor (edge device or the equivalent).
<b>Type D</b>	Actuating device requiring continuous pressure to maintain opening or closing motion of the gate.

Minimum Quantity of Entrapment Protection Means		
	Opening	Closing
Horizontal Slide Gate	2*	2*

\*The Inherent ERD System (Type A) counts as 1 entrapment protection device in each direction. Therefore, a minimum of one more exterior entrapment protection device (type B1 or B2) needs to be installed in each direction.

## EMX - NIR-50-325 - PHOTO EYE WIRING DIAGRAM

**Figure 10**

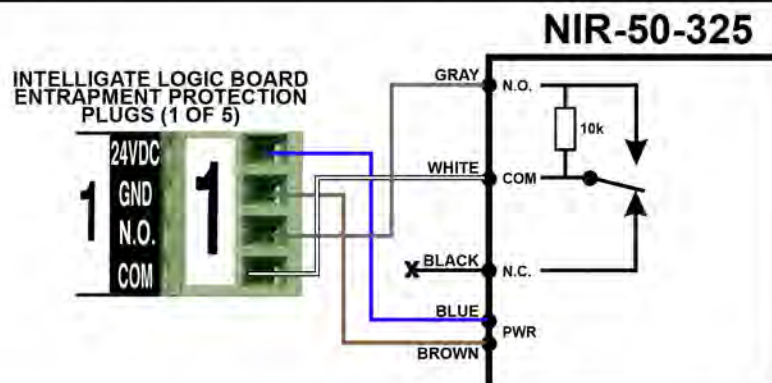

# ENTRAPMENT PROTECTION AREA



## WARNING

**MAKE SURE ALL ENTRAPMENT ZONES ARE PROTECTED BY APPROVED ENTRAPMENT PROTECTION DEVICES.**

**ENTRAPMENT ZONE:** Locations between a moving gate and a counter opposing edge or surface where entrapment is possible up to 6ft. above grade. Such locations occur if during any point in travel the gap between a moving gate and fixed counter opposing edges or surfaces is less than 16 inches.

- A Maximum of 10 entrapment protection devices may be connected to your operator (Depending on direction of travel protected and type of device)
- Make sure all entrapment zones are protected by an approved entrapment protection device.

### Approved entrapment protection devices:

- |                          |   |
|--------------------------|---|
| - EMX NIR 50-325         | - MILLER EDGE - PRIME GUARD             |
| - EMX IRB-MON            | - MILLER EDGE - REFLECTI-GUARD          |
| - EMX IRB-RET            | - SECO-LARM - "ENFORCER" - E931-S50RRGQ |
| - OMRON - E3K-R10K4-NR-1 | - SECO-LARM - "ENFORCER" - E936-S45RRGQ |

**Figure 11**

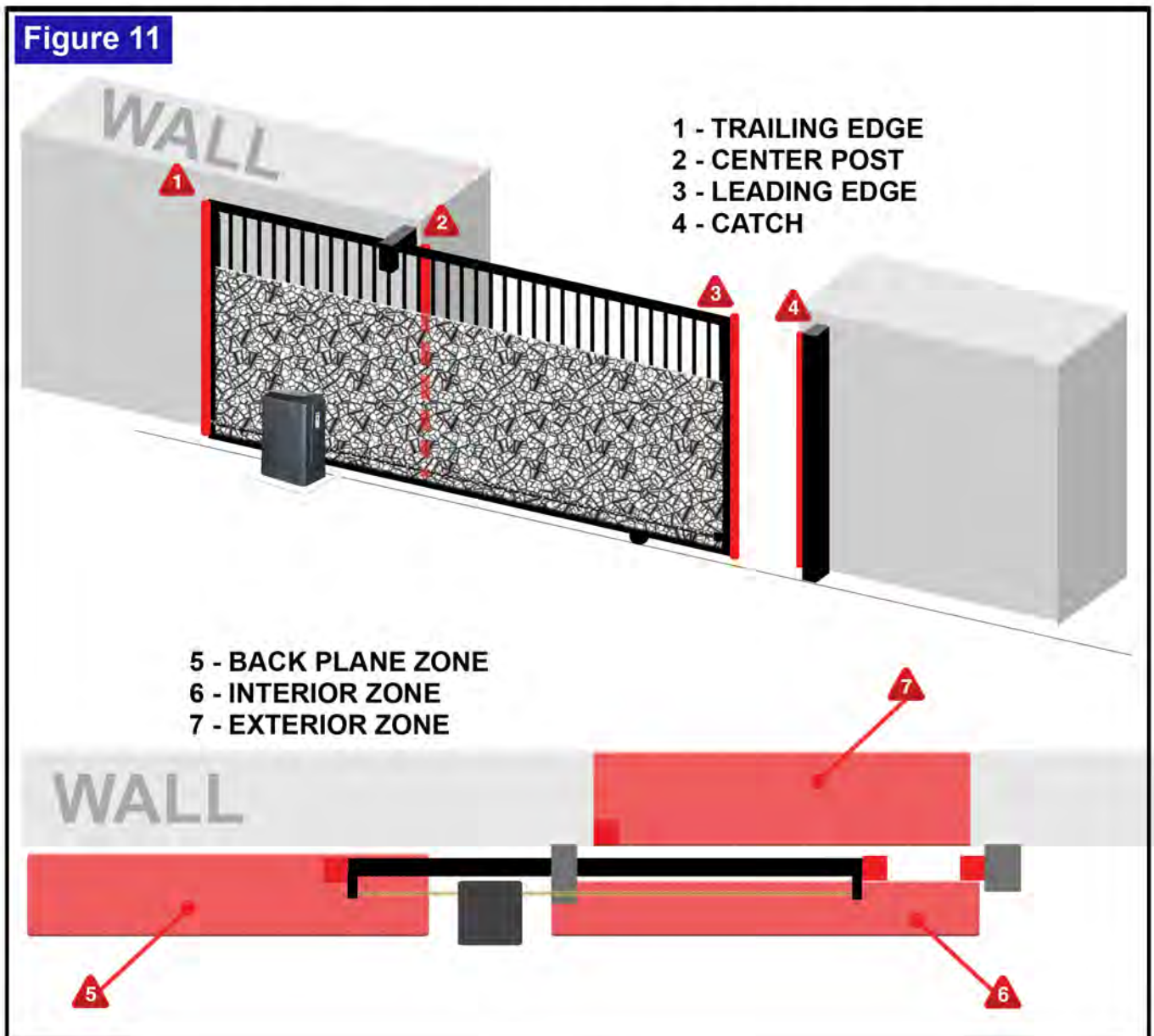

# LOGIC & AC DRIVER BOARD - L.E.D. LAYOUT

## LOGIC BOARD



- POWER - Low voltage is present.
- OPENING - The gate is opening.
- STOPPED - The gate is stopped.
- CLOSING - The gate is closing.
- FULL OPEN - The open limit switch is being triggered.
- FULL CLOSED - The close limit switch is being triggered.
- 3BTN OPEN - 3-button station "open" button is being pressed.
- 3BTN STOP - 3-button station "stop" button is being pressed.
- 3BTN CLOSE - 3-button station "close" button is being pressed.
- PR/CO WARN - Pre-warn / Constant-warn relay is active.

- SAFETY - Safety / Reversing device is being triggered.
- FIREBOX - Firebox device is being triggered.
- EXIT - Exit device is being triggered.
- PHANTOM - Phantom device is being triggered.
- RADIO - Radio device is being triggered
- MAG/SOL - The magnetic / solenoid lock relay is active.
- INS DET - The inside detector is being triggered.
- LED 1 - Not used at this time.
- LED 2 - Not used at this time.
- LED 3 - Not used at this time.

- PRI ERD - ERD on the primary unit is being triggered.
- PRI XCOM - Communication on the primary unit is sending / receiving information.
- SEC ERD - ERD on the secondary unit is being triggered.
- SEC XCOM - Communication on the secondary unit is sending / receiving a signal
- SEC FP - The foot pedal switch on the secondary unit is being triggered.
- ENTRAP 1 - A monitored entrapment device on Entrapment #1 is being triggered.
- ENTRAP 2 - A monitored entrapment device on Entrapment #2 is being triggered.
- ENTRAP 3 - A monitored entrapment device on Entrapment #3 is being triggered.
- ENTRAP 4 - A monitored entrapment device on Entrapment #4 is being triggered.
- ENTRAP 5 - A monitored entrapment device on Entrapment #5 is being triggered.

## AC DRIVER BOARD



- POWER - Low voltage is present.
- MOTOR 1 - Motor 1 is running.
- MOTOR 2 - Motor 2 is running.
- STOPPED - Gate is stopped.
- XCOM - Communication is sending / receiving information.
- AUX 1 - 1st auxiliary input.
- LED 1 - Not used at this time.

- ERD - ERD is being triggered.
- FOOT PEDAL - The foot pedal switch is being triggered.
- LIMIT 1 - Limit 1 limit switch is being triggered.
- LIMIT 2 - Limit 2 limit switch is being triggered.
- SLOW/INITLZ - Slow start & slow stop is being initialized.
- AUX 2 - 2nd auxiliary input.
- LED 2 - Not used at this time.

# LOGIC BOARD DIP SWITCHES & PUSHBUTTONS

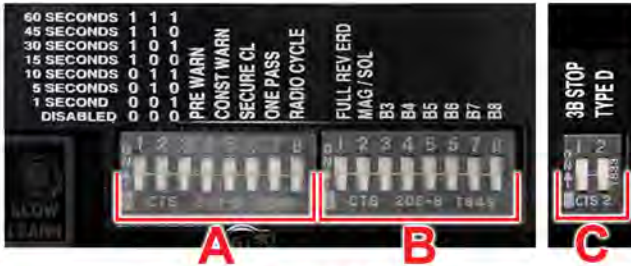

## DIP SWITCH 'A'

### 'A' 1, 2 & 3 - AUTOMATIC CLOSE TIMER

'0' = ↓ DOWN    '1' = ↑ UP

SWITCH	1	2	3	GATE OPEN DURATION
	0	0	0	DISABLED
	0	0	1	0 SECONDS
	0	1	0	5 SECONDS
	0	1	1	10 SECONDS
	1	0	0	15 SECONDS
	1	0	1	30 SECONDS
	1	1	0	45 SECONDS
	1	1	1	60 SECONDS

### 'A' 4 - PRE WARN ALARM

<b>DOWN</b>	Normal Operation
<b>UP</b>	Triggers a closed contact between 'CON/PRE WARN' outputs (located on relay connections plug) for 3 seconds before the gate moves in any direction.

### 'A' 5 - CONSTANT WARN ALARM

<b>DOWN</b>	Normal Operation
<b>UP</b>	Triggers a closed contact between 'CON/PRE WARN' outputs (located on relay connections plug) whenever the motor is running.

\* If both 'A' 4 & 'A' 5 are in the up position then there will be a closed contact on the con/pre warn outputs for 3 seconds before and as the motor is running.

### 'A' 6 - SECURE CLOSE

<b>DOWN</b>	Normal Operation
<b>UP</b>	When power is lost and then regained, if all devices are clear & it's safe, the gate will close

### 'A' 7 - ONE PASS

<b>DOWN</b>	Normal Operation
<b>UP</b>	While the gate is opening, if the rev loop input is triggered and then cleared, the gate will immediately start closing. If the rev loop is then triggered again, before the gate is fully closed, the gate will stop and stay at rest until the rev loop input is cleared. Once the rev loop input is cleared, the gate will resume closing. At any time if a valid open signal is received, the gate will open.

### 'A' 8 - RADIO CYCLE

<b>DOWN</b>	The gate will close, if it's on the open limit. Otherwise, the gate will always open.
<b>UP</b>	The gate will close if it's on the open limit. The gate will open if it's on the close limit. If in travel, the gate will stop with the 1st command and reverse with a second command.

## DIP SWITCH 'B'

### 'B' 1 - FULL REVERSE ERD

<b>DOWN</b>	Normal Operation. If an obstruction is sensed, the gate will stop and reverse for 1 second.
<b>UP</b>	If an obstruction is sensed: Opening - Gate will stop and reverse for 1 sec. Closing - Gate will stop and reverse until fully open.

### 'B' 2 - MAGNETIC/SOLENOID LOCK

<b>DOWN</b>	Magnetic Lock - MAG/SOL relay is shorted when the gate is closed or closing.
<b>UP</b>	Solenoid Lock - MAG/SOL relay is shorted for 2 seconds when the gate starts to open.

### 'B' 3 thru 8 - NOT USED AT THIS TIME

## DIP SWITCH 'C'

### 'C' 1 - 3B STOP

<b>DOWN</b>	3-button station - The 'STOP' input is active. A normally-closed contact switch must be present between 'common' and 'stop'
<b>UP</b>	3-button station - The 'STOP' input is bypassed. No connection between 'common' and 'stop' is needed.

### 'C' 2 - TYPE D\*\*

<b>DOWN</b>	Type D device* is not being used to meet UL325 standards.
<b>UP</b>	Type D device* is being used to meet UL325 standards. This disables all inputs other than the 3-button station. Maintained signal required.

\* Type D device - A pushbutton or equivalent that required a maintained pressure for activation.

\*\*For gate operators utilizing Type D protection:

- 1) The gate operator controls must be placed so that the user has full view of the gate area when the gate is moving.
- 2) The placard as required by UL3.25 - 62.1.6 shall be placed adjacent to the controls.
- 3) An automatic closing device (such as a timer, loop sensor, or similar device) shall not be employed, and
- 4) No other activation device shall be connected.

## PUSHBUTTONS



### E.P. LEARN Monitored Entrapment Protection Learn Button

Activates the monitored entrapment protection learning process. This button is to be pressed after the entrapment protection devices are connected to the board. During this process, the LEDs will blink. The processor will check for devices connected. Once this process is complete, the LEDs will return to normal operation and the processor will monitor for the 'learned' devices connected. (For further information, see the Entrapment Protection section of this manual.)

# ENTRAPMENT PROTECTION DIP SWITCHES & PLUGS

## ENTRAPMENT PROTECTION



**D**

**E**

### DIP SWITCH 'D & E'

#### 'D'1, 'D'2 & 'D'3 - \*M.E.P. #1

'0' = ↓DOWN '1' = ↑UP

SWITCH	D1	D2	D3	GATE OPEN DURATION
	0	0	0	NO DEVICE CONNECTED
	0	0	1	NO DEVICE CONNECTED
	0	1	0	PHOTO EYE ON CLOSING
	0	1	1	EDGE ON CLOSING
	1	0	0	PHOTO EYE ON OPENING
	1	0	1	EDGE ON CLOSING
	1	1	0	PHOTO EYE ON OPENING & CLOSING
	1	1	1	EDGE ON OPENING & CLOSING

#### 'D'4, 'D'5 & 'D'6 - \*M.E.P. #2

'0' = ↓DOWN '1' = ↑UP

SWITCH	D4	D5	D6	GATE OPEN DURATION
	0	0	0	NO DEVICE CONNECTED
	0	0	1	NO DEVICE CONNECTED
	0	1	0	PHOTO EYE ON CLOSING
	0	1	1	EDGE ON CLOSING
	1	0	0	PHOTO EYE ON OPENING
	1	0	1	EDGE ON CLOSING
	1	1	0	PHOTO EYE ON OPENING & CLOSING
	1	1	1	EDGE ON OPENING & CLOSING

#### 'D'7, 'D'8 & 'E'1 - \*M.E.P. #3

'0' = ↓DOWN '1' = ↑UP

SWITCH	D7	D8	E1	GATE OPEN DURATION
	0	0	0	NO DEVICE CONNECTED
	0	0	1	NO DEVICE CONNECTED
	0	1	0	PHOTO EYE ON CLOSING
	0	1	1	EDGE ON CLOSING
	1	0	0	PHOTO EYE ON OPENING
	1	0	1	EDGE ON CLOSING
	1	1	0	PHOTO EYE ON OPENING & CLOSING
	1	1	1	EDGE ON OPENING & CLOSING

\* M.E.P. = Monitored Entrapment Protection

#### 'E'2, 'E'3 & 'E'4 - \*M.E.P. #4

'0' = ↓DOWN '1' = ↑UP

SWITCH	E2	E3	E4	GATE OPEN DURATION
	0	0	0	NO DEVICE CONNECTED
	0	0	1	NO DEVICE CONNECTED
	0	1	0	PHOTO EYE ON CLOSING
	0	1	1	EDGE ON CLOSING
	1	0	0	PHOTO EYE ON OPENING
	1	0	1	EDGE ON CLOSING
	1	1	0	PHOTO EYE ON OPENING & CLOSING
	1	1	1	EDGE ON OPENING & CLOSING

#### 'E'5, 'E'6 & 'E'7 - \*M.E.P. #5

'0' = ↓DOWN '1' = ↑UP

SWITCH	E5	E6	E7	GATE OPEN DURATION
	0	0	0	NO DEVICE CONNECTED
	0	0	1	NO DEVICE CONNECTED
	0	1	0	PHOTO EYE ON CLOSING
	0	1	1	EDGE ON CLOSING
	1	0	0	PHOTO EYE ON OPENING
	1	0	1	EDGE ON CLOSING
	1	1	0	PHOTO EYE ON OPENING & CLOSING
	1	1	1	EDGE ON OPENING & CLOSING



Set the dip switches to match with the corresponding \*M.E.P. plug.

All four (4) wires must be connected for the \*M.E.P. to properly function.

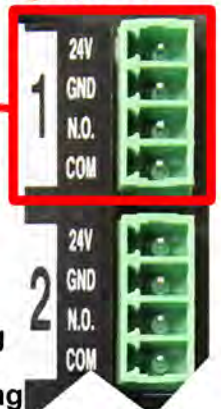

- OPEN - Used to protect during the open cycle.
- CLOSE - Used to protect during the close cycle.
- PHOTO/EDGE - The type of device that is being connected.  
DOWN = photo eye  
UP = edge connector

# LOGIC BOARD PLUGS

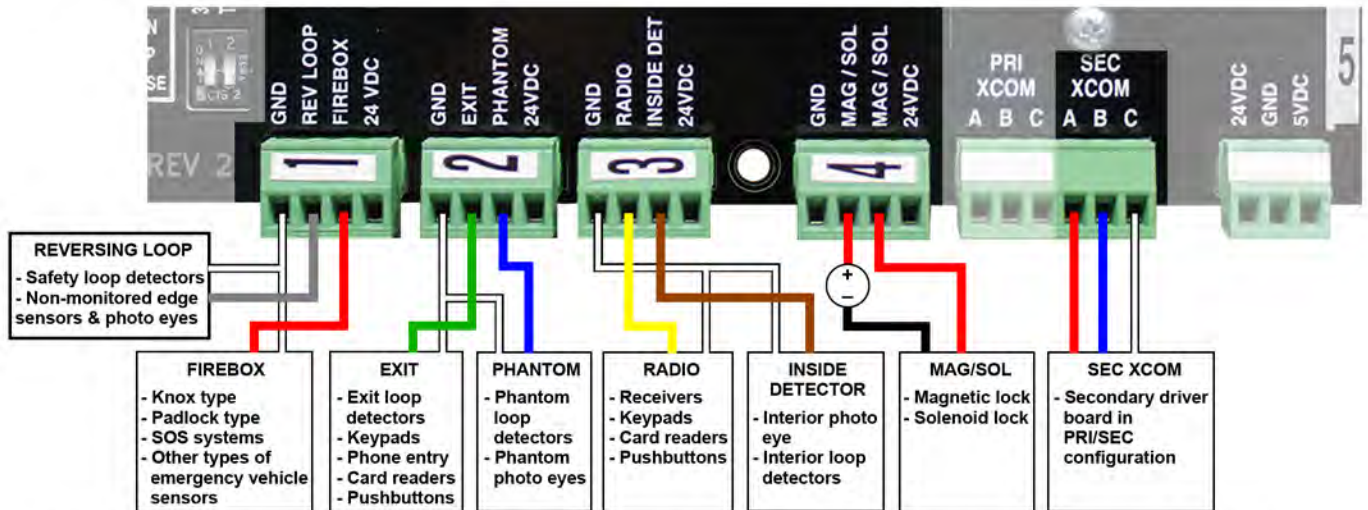

- **REV LOOP** - Used to stop the gate from closing. Holds the gate open when maintained. This is a non-monitored connection. Monitored devices should be connected to the entrapment protection plugs.
- **FIREBOX** - Used to open the gate for emergency vehicles. Requires a maintained signal. Overrides all safety devices.  
\*ONLY USE FOR EMERGENCY VEHICLES.
- **EXIT** - Used to open the gate and/or hold the gate open.
- **PHANTOM** - Used to hold the gate open when it's on the open limit. Once the gate starts to close this has no effect. Works with a loop detector or photo eye to cover the area that the gate travels over.
- **RADIO** - Used to open, stop and close the gate. Full control.
- **INSIDE DET** - Stops a swing gate from hitting an obstruction when opening. When triggered, the gate will stop and wait until the detector is cleared. Once the detector is cleared, the gate will continue to open.
- **MAG/SOL** - Used with a magnetic lock or solenoid. See dip switch 'B4'. This is a relay output. A separate transformer or power source is needed to work with this connection.  
MAG: The relay is closed when the gate is closing or closed.  
SOL: The relay is closed for 3 seconds as it begins to open, then releases.
- **SEC XCOM** - 3-wire conductor, preferably shielded, used to communicate between the primary and secondary units.

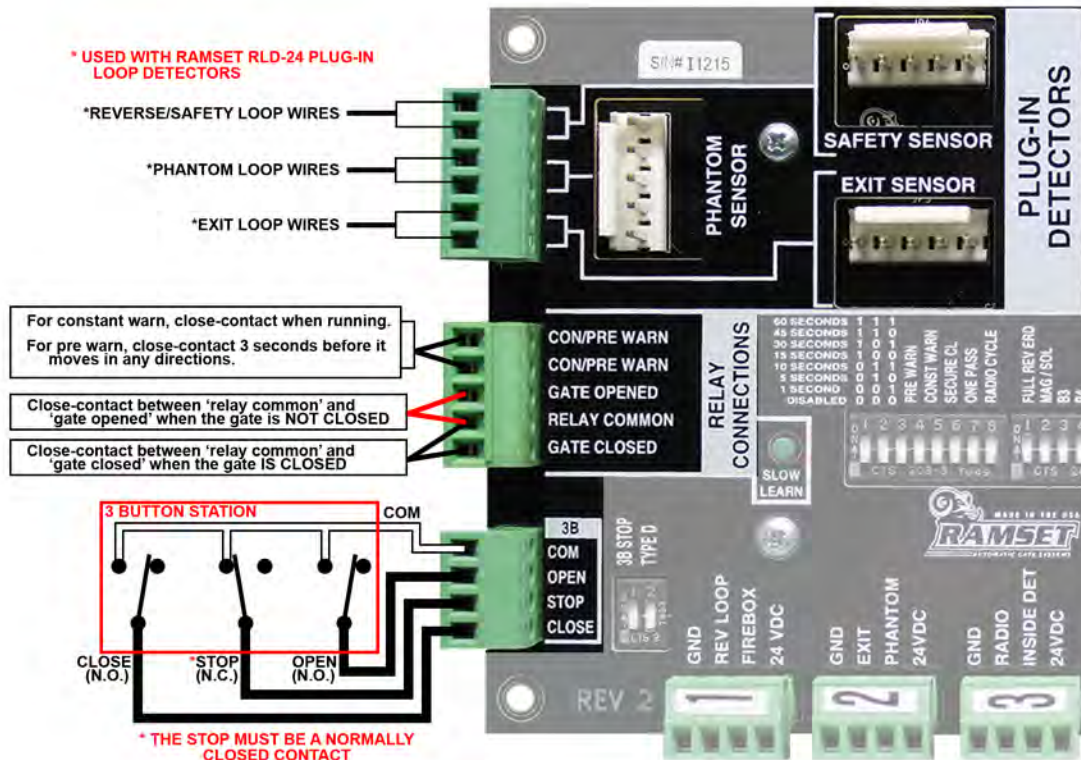

# AC DRIVER BOARD DIP SWITCHES & PUSHBUTTONS

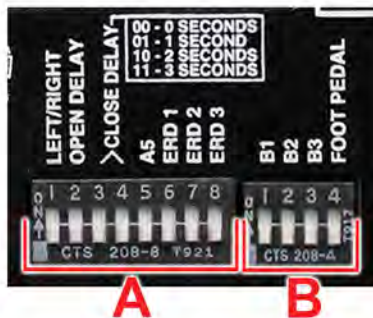

## DIP SWITCH 'A'

### 'A' 1 - LEFT / RIGHT

DOWN	Left hand installation
UP	Right hand installation

**\*POINT OF VIEW - Standing on the same side of the gate the operator is installed on, looking through the gate opening.**  
 Operator on the Left = Left hand installation  
 Operator on the Right = Right hand installation

### 'A' 2 - OPEN DELAY

DOWN	No delay on opening.
UP	1 SECOND DELAY ON OPENING

### 'A' 3 & 4 - CLOSE DELAY

'0' = ↓DOWN      '1' = ↑UP

SWITCH	3	4	AMOUNT OF DELAY
	0	0	NO DELAY ON CLOSING
	0	1	1 SECOND DELAY ON CLOSING
	1	0	2 SECOND DELAY ON CLOSING
	1	1	3 SECOND DELAY ON CLOSING

### 'A' 5 - MOTOR Hp - ERD

DOWN	1/2Hp 115VAC MOTORS
UP	3/4Hp & 1Hp 115VAC MOTORS

### 'A' 6, 7 & 8 - ERD 1, 2 & 3

'0' = ↓DOWN      '1' = ↑UP

SWITCH	6	7	8	SENSITIVITY
	0	0	0	MOST SENSITIVE (LIGHT GATE)
	0	0	1	HIGH SENSITIVITY
	0	1	0	MEDIUM-HIGH SENSITIVITY
	0	1	1	MEDIUM SENSITIVITY
	1	0	0	MEDIUM SENSITIVITY
	1	0	1	MEDIUM LOW SENSITIVITY
	1	1	0	LOW SENSITIVITY
	1	1	1	LEAST SENSITIVE (HEAVY GATE)

## DIP SWITCH 'B'

'B' 1, 2 & 3 - NOT USED AT THIS TIME

### 'B' 4 - FOOT PEDAL

DOWN	Used on units that have a foot pedal. When the foot pedal is 'down', then no operation.
UP	'UP' on units that do not have a foot pedal.

## PUSHBUTTONS



- OPEN - Opens the gate. When held down, in emergencies, it will override the monitored safety devices
- STOP - Stops the gate.
- CLOSE - Closes the gate. When held down, in emergencies, it will override the monitored safety devices.



# AC DRIVER BOARD PLUGS & FUNCTIONS

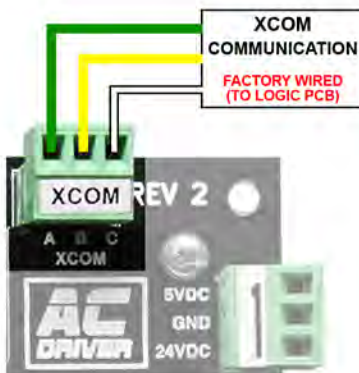
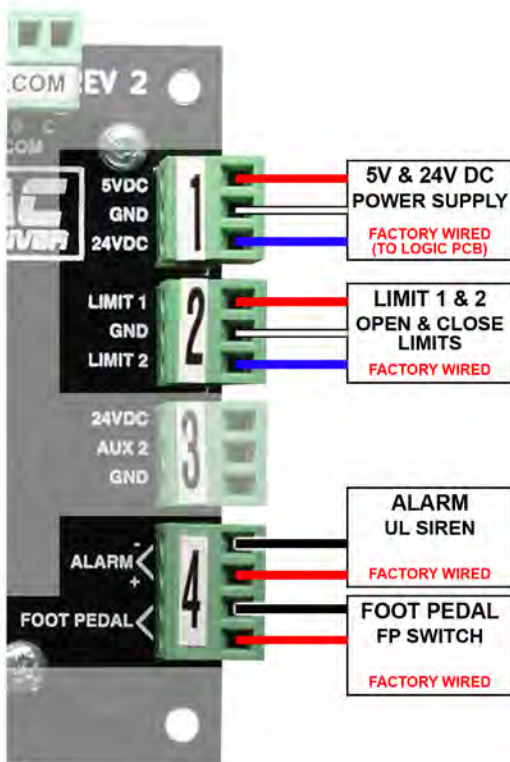
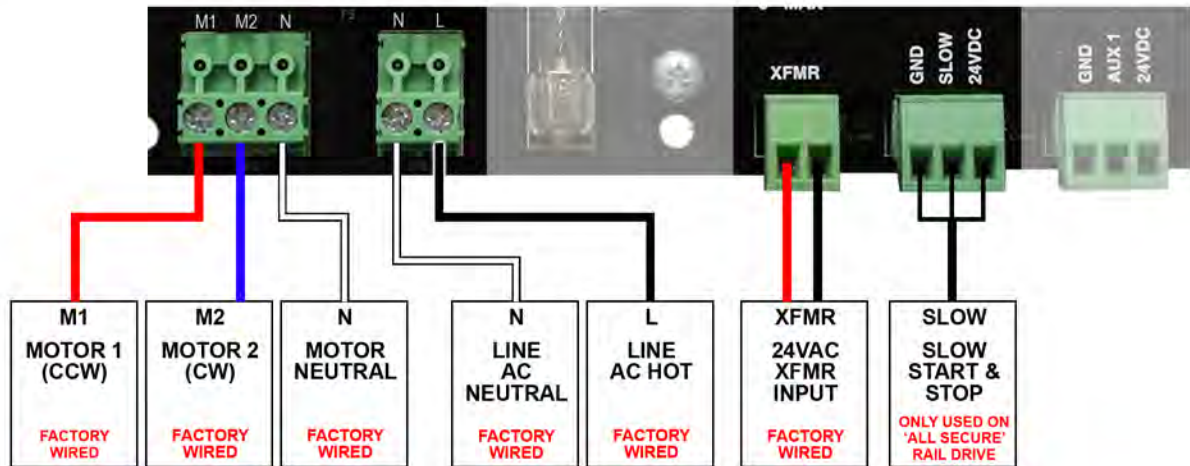

- M1 - MOTOR 1 - 1 of 3 motor wires. CCW (counter-clockwise) terminal on the motor.
- M2 - MOTOR 2 - 1 of 3 motor wires. CW (clockwise) terminal on the motor.
- N - MOTOR NEUTRAL - 1 of 3 motor wires. Neutral / Com common terminal on the motor.
- N - LINE AC NEUTRAL - High voltage input neutral wire (from breaker)
- L - LINE AC HOT - High voltage input hot wire (from power switch)
- XFMR - Low voltage input from transformer (No Polarity)
- SLOW - Input for the slow stop switch (only available on the All Secure Rail drive gate operator)

- 5V & 24V DC POWER SUPPLY - Low voltage supply from the logic board.
- LIMIT 1 & 2 - Open & close limit switch wire inputs. Open & close is determined by the left / right dip switch.
- ALARM - UL ERD warning alarm input. Factory installed alarm that sounds when an obstruction is triggered twice in one travel. When triggered, the output of the plug is 24VDC.
- FOOT PEDAL - Input for the foot pedal switch located on the foot pedal assembly. When triggered open, this puts the gate operator into 'manual mode'. When triggered short, this puts the gate operator into 'Automatic Mode'. On units without a foot pedal, the dip switch "FOOT PEDAL" should be in the 'ON' position.

- XCOM - 3 wire terminal used for communication between the logic and AC driver board.

## PRIMARY / SECONDARY - BI-PARTING GATES

- Connect a 3-wire, shielded cable (not supplied), between 'SEC XCOM' on the Logic Board in the Primary Unit and 'XCOM' on the AC Driver Board in the Secondary Unit.
- The Primary / Secondary wires should be ran in a conduit separate from power.

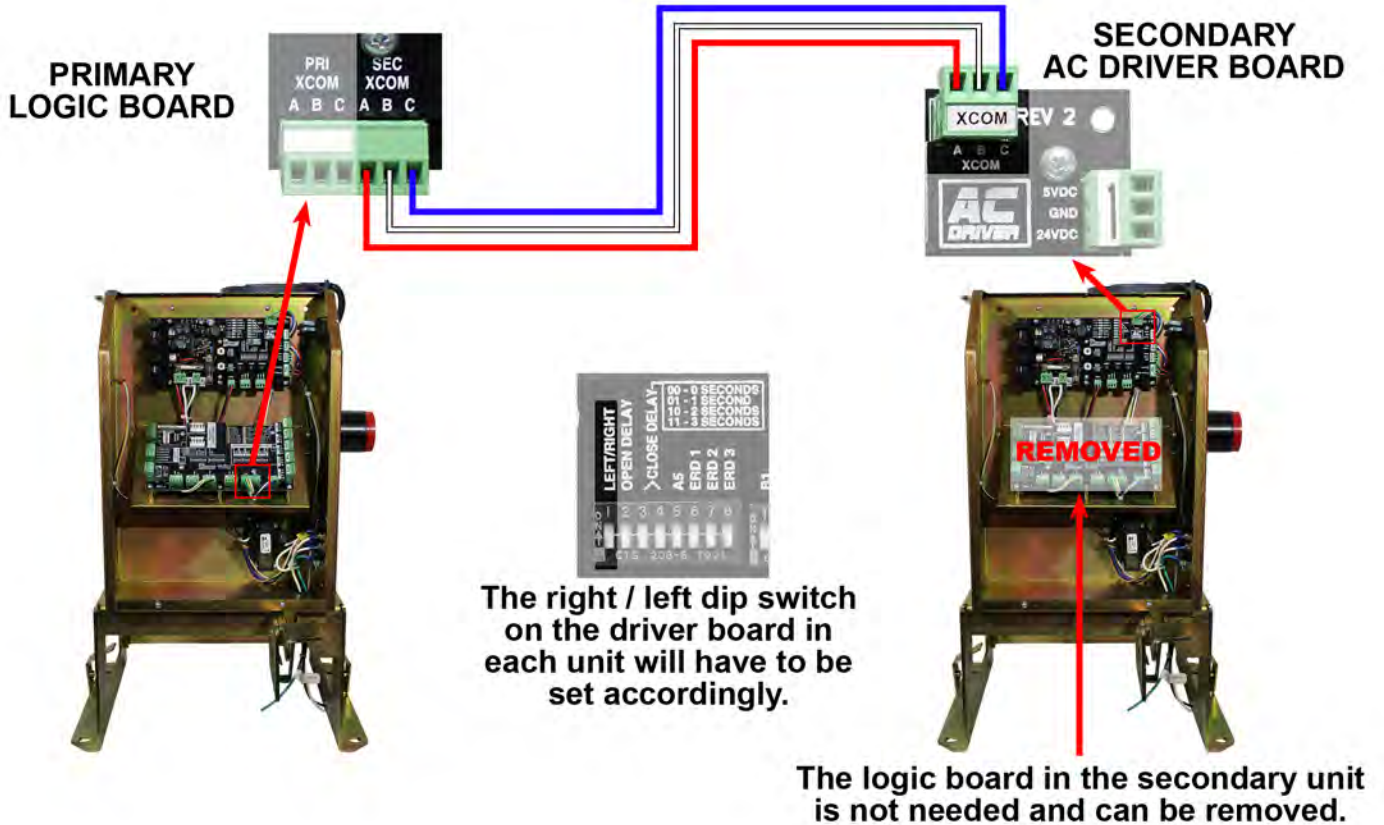

## FOOT PEDAL EMERGENCY RELEASE



### WARNING

FOOT PEDALS SHOULD NOT BE USED ON INSTALLATIONS WITH STEEP INCLINES. GATES SHALL BE DESIGNED, CONSTRUCTED AND INSTALLED SUCH THAT THEIR MOVEMENT SHALL NOT BE INITIATED BY GRAVITY WHEN AN AUTOMATIC OPERATOR IS DISCONNECTED.

### EMERGENCY RELEASE

1. Turn off all power from the operator at the breaker.
2. Remove the pad lock or bolt, if present.
3. Step down on the foot pedal (locks in down position)
4. To re-engage, lightly kick the foot pedal to the right, foot pedal will pop back up.

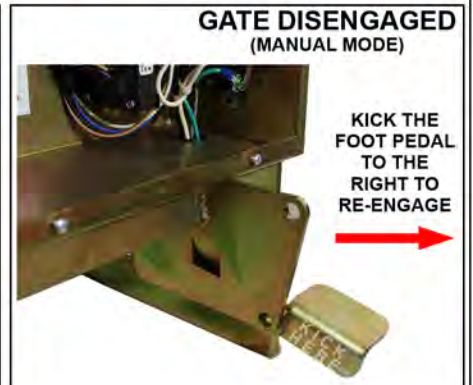
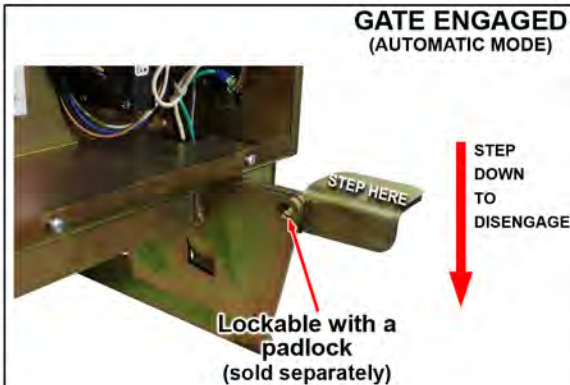

# LOGIC PCB TO AC DRIVER PCB - FACTORY WIRING

## LOGIC CONTROL BOARD

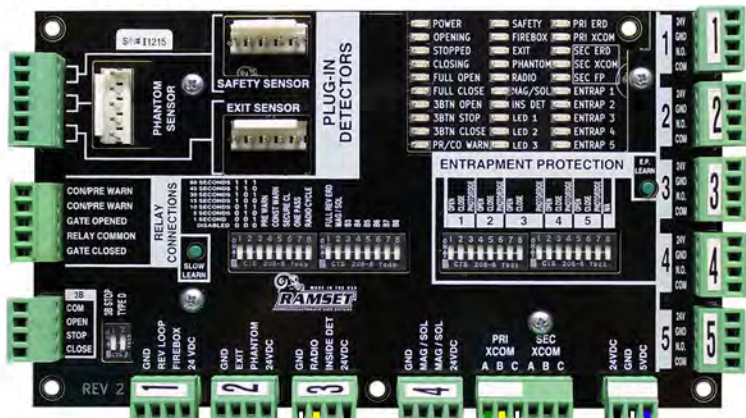

## AC DRIVER CONTROL BOARD

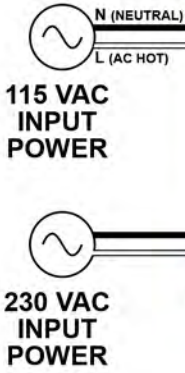
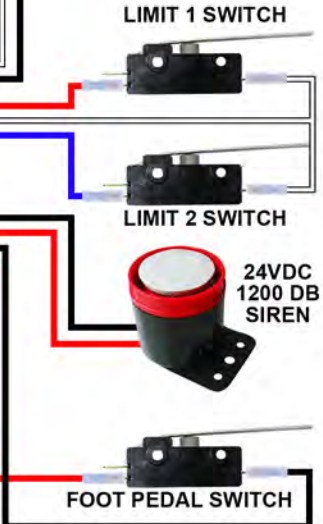
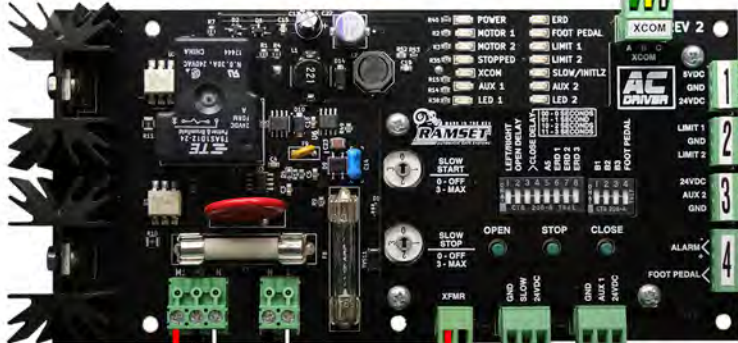

## (M.E.P.) MONITORED ENTRAPMENT PROTECTION QUICK SETUP GUIDE



**IMPORTANT: MAKE SURE THE M.E.P. DEVICE YOU ARE USING IS A UL325 MONITORED ENTRAPMENT DEVICE USING THE 10K METHOD**

1. Slide Gate Requirements:
  - a. Closing - Minimum 1 photo eye or edge sensor.
  - b. Opening - Minimum 1 photo eye or edge sensor.
2. Swing Gate Requirements:
  - a. Closing - Minimum 1 photo eye or edge sensor.
  - b. Opening - No minimum requirement.
3. M.E.P. #1
  - a. Connect 4 wires (24V, GND, N.O. & COM) to the #1 plug (located on the right edge of the logic board # 1 thru #5)
  - b. Set the corresponding dip switches  
[MEP 1 = Dip switch section 1 (C1, C2, C3)...]
    - if protecting the opening, turn the 'OPEN' dip switch on.
    - if protecting the closing, turn the 'CLOSE' dip switch on.
    - if using a photo eye, turn the 'PHOTO/EDGE' switch off.
    - if using a edge sensor, turn the 'PHOTO/EDGE' switch on.
4. M.E.P. #2 (if applicable)
  - a. Connect 4 wires (24V, GND, N.O. & COM) to the #2 plug (located on the right edge of the logic board # 1 thru #5)
  - b. Set the corresponding dip switches  
[MEP 2 = Dip switch section 2 (C4, C5, C6)...]
    - if protecting the opening, turn the 'OPEN' dip switch on.
    - if protecting the closing, turn the 'CLOSE' dip switch on.
    - if using a photo eye, turn the 'PHOTO/EDGE' switch off.
    - if using a edge sensor, turn the 'PHOTO/EDGE' switch on.
5. Continue through M.E.P. #5 or until all MEP devices are connected.
6. Once all M.E.P. devices are connected, push & hold the 'EP LEARN' button.
  - a. When LEDs 'ENTRAP 1' through 'ENTRAP 5' start flashing, release the button.
  - b. All 5 LEDs will go off for about 3 seconds.
  - c. All 5 LEDs will blink 3 times.
  - d. The corresponding LEDs with the MEPs that were connected will turn solid for 3 seconds. (make sure the number of LEDs match the number of MEPs connected. If the numbers don't match, check the wiring connection and repeat step 6.